

## SUP30A-1WPC-WS

### Summary

SUP30A-1WPC-WS is a constant current output LED dimming driver. The driver supports 0-10V edge signal, PWM and adjustable resistor signals achieve smooth dimming effect.

### Product Features

- Single channel output, the output current can be selected through software.
- 0-10V dimming
- Class 2 power supply
- NTC External over temperature protection
- Protection: Overload, overvoltage, short circuit, NTC protection
- Suitable for indoor LED lighting applications

### Application



Down Light

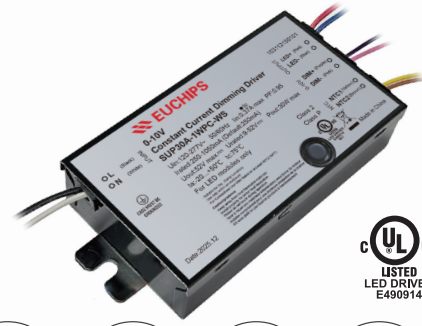

Flicker free



0-10V



Programming Current



Short Circuit Protection



Over Load Protection



Over Current Protection

### Technical Parameters

Model	SUP30A-1WPC-WS	
Input	Efficiency	85%@120VAC,full load 86%@277VAC,full load
	Frequency Range(Hz)	50/60Hz
	Voltage	120VAC-277VAC
	PF	≥0.95@120VAC, ≥0.9@277VAC, full load
	THD(full load)	≤10%@120VAC, ≤15%@277VAC, full load
	Current	0.37Amax@120VAC, 0.25Amax@230VAC, 0.17Amax@277VAC
	Inrush current	Cold start,8.68A@120VAC 156us, 19.9A@277VAC 156us
	Standby power	≤0.5W
	No load power	<1W
	Turn on delay Time	≤ 0.75s, @120Vac (When the light begins to shine)
Output	Current	250-1050mA (Set the current through software) (Default:250mA)
	Voltage	9-52V
	Power	30W
	Channel	1
	No load output voltage	59V Max
	Current Accuracy	±5%
	Ripple Voltage	±3%
Protection	Short circuit	No output, self recovery after removing the fault
	Over Voltage	Output voltage>52V hiccup protection, troubleshooting and normal output
	Over load	Reduce current hiccup protection, troubleshoot and output normally
	NTC	External over temperature protection: NTC external resistor (50K Thermistor) is placed inside the lamp. When the temperature rises to the set value, it drives a current reduction output, Prevent lighting fixtures from overheating and extend their service life
Safety & EMC	Surge	L-N:2.5KV LN-G:2.5KV
	Withstand Voltage	I/P-O/P: 2000Vac/1min/<5mA I/P-PG: 1500Vac/1min/<5mA O/P-PG: 500Vac/1min/<5mA O/P-O-10V: 500Vac/1min/<5mA
	Safety standards	UL8750/UL1310/CSA25013,CSA class P; EN 61347-1/EN 61347-2-13
	EMI	FCC class B(120V)/class A(277V) EN55015,EN61000-3-2 Class C,IEC61000-3-3
	EMS	EN61000-4-2, 3, 4, 5, 6, 8, 11; EN61547
	Insulation Resistance	5MΩ
Function	Dimming type	0-10V
	Dimming range	1%-100%
	Dimming curve	0-10V Linearity (User editable and modifiable)
	Flicker	Flicker free
Others	IP rating	IP20
	Working temp.	(-20~+50) °C [-4°F~122°F]
	Storage Temp., Humidity	-40°C~85°C [-40°F~185°F], 20-90%RH
	tc	75°C [ 167°F ] for safety & life
	Lifetime	50,000h@tc:75°C[ 167°F ]
	Warranty	5 years
	Switch cycle	>25,000 times
	Material	Metal
	Dimension	130*60.5*26mm(5.12*2.38*1.02 Inch)(L*W*H)
Packing size	Net weight: 370g(0.815 lb)±5%/PCS; 36PCS/ Carton; 13.82kg(30.46lb)±5%/Carton; Carton Size: 469x343x240mm(18.46*13.5*9.44 Inch)(L*W*H)	

## Dimension(mm)

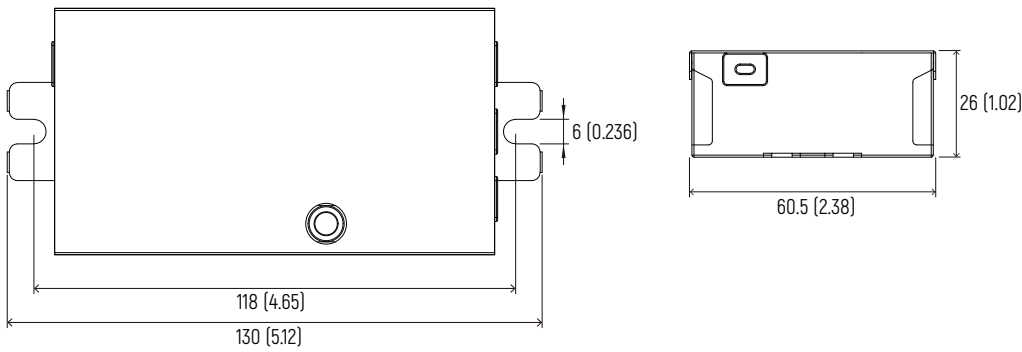

## Wiring Diagram

Metal case

All material to be ROHs compliant to Directive 2002/95/EC

Wires to be Stranded with UL approval

Input: Black & White: 320mm , 18AWG

Output: Red & Blue: 320mm , 18AWG

0-10V: Purple & Pink: 320mm , 22AWG

NTC: Yellow & Brown: 320mm , 22AWG

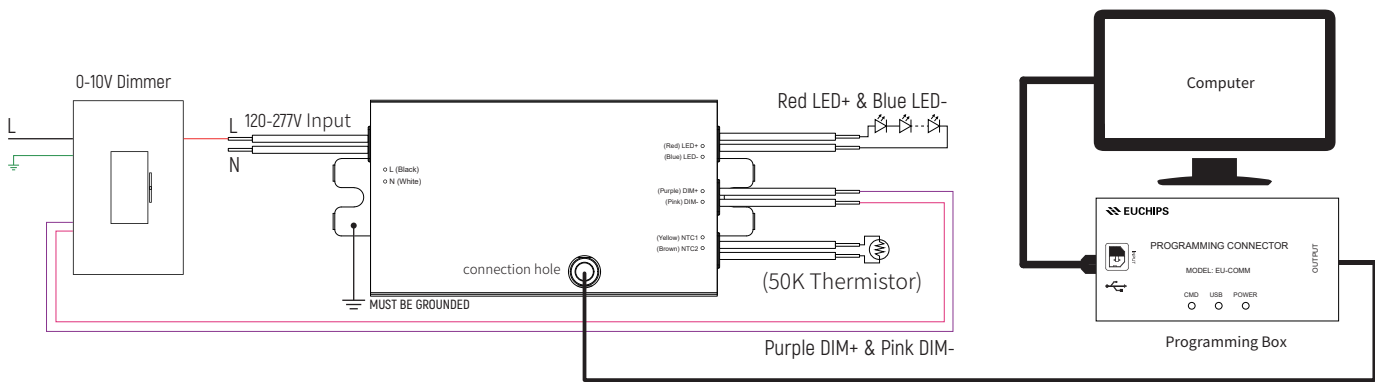

## Configurable functions

- Data log reading: SKU, serial number, batch number, FW revision version
- Output current regulation (factory default: 250)
- Dimming depth editing (factory default: see technical parameter table, editable range 10% Max)
- Dimming curve editing. Built in linear and logarithmic fixed curves, can be directly selected for use. At the same time, it has built-in custom curves and supports editing curves.
- Support parameter copying/replication and batch editing.

EU-PROG User Manual, Please click the link to view.

<https://v2.fangcloud.com/share/2549f7729789c1c5ad5be53728>

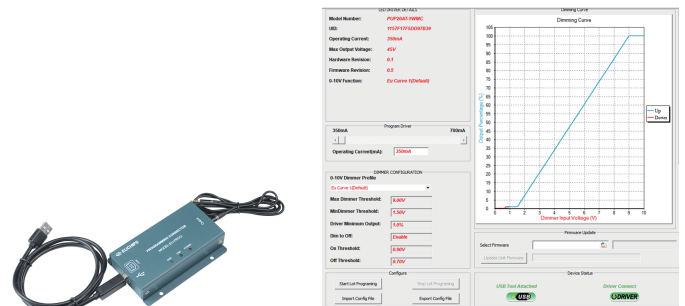

EU-PROG Programming connector

Interface

## 0-10V Dimming curve

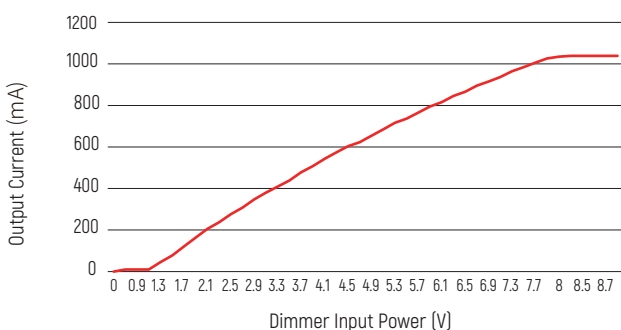

## PF vs Load Curve

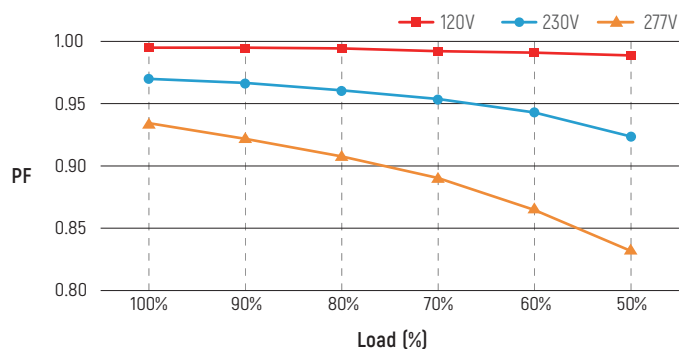

### THD vs Load Curve

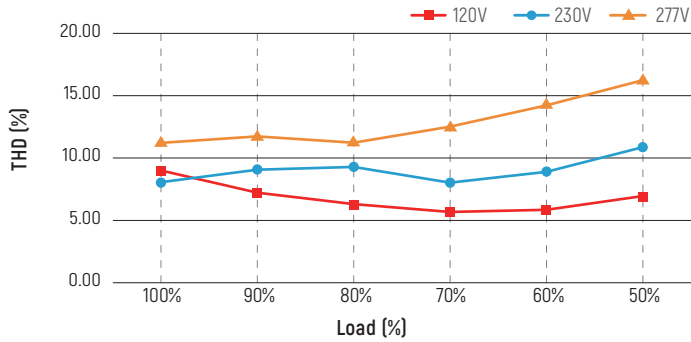

### Efficiency vs Load Curve

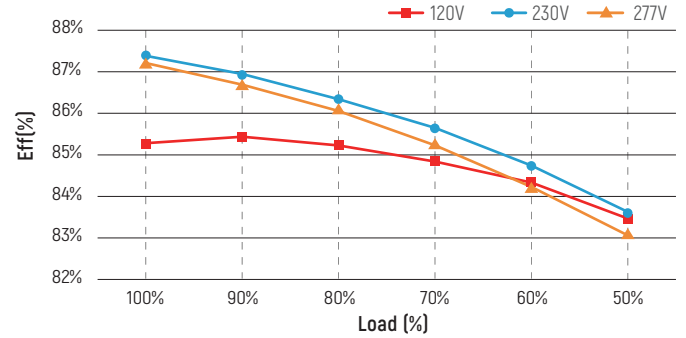

### Derating Curve

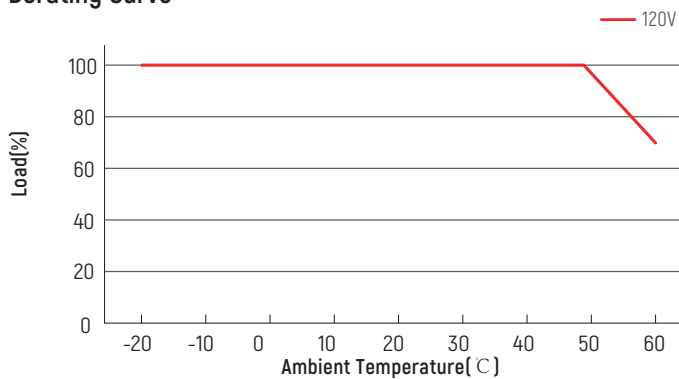

### Life-time vs. case temperature

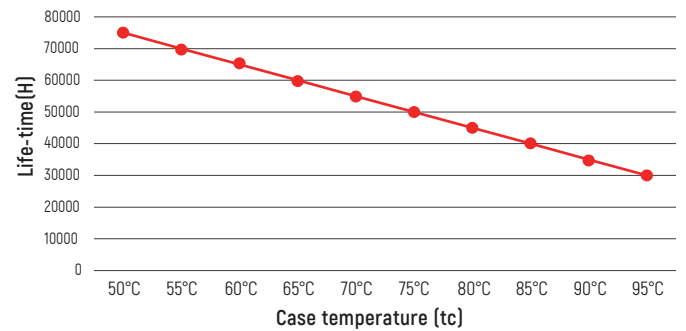

The life-time of the led driver is shown in the figure above (calculated based on the 90% survival rate).

The relation of  $t_c$  to  $t_a$  temperature depends also on the luminaire design.

### LED Thermal Protection (NTC) Characteristic

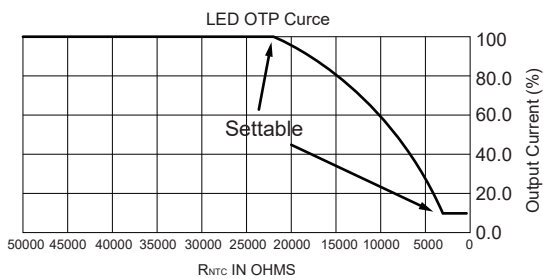

Graphs for reference. The derating limits can be programmed using the Light Touch. In the end application, care must be taken to place the NTC thermistor close to the hottest spot on the LED module. If LED thermal protection is not required the NTC port on the LED power supply connector can be left open.

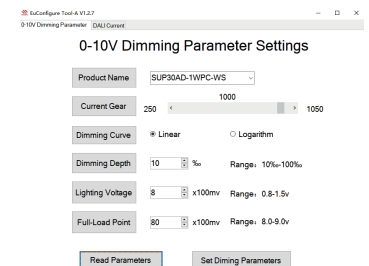

### Max. quantity of drivers per miniature circuit breaker

Specification item	Value	Value	Condition
Inrush current $I_{peak}$	8.68A (120V)	19.9A (277V)	Input Voltage 120V/277V
Inrush current $T_{width}$	156us (120V)	277us (277V)	Input Voltage 120V/277V, measured to 50% $I_{peak}$

MCB	Input Voltage 120V Drivers	Input Voltage 277V Drivers	MCB	Input Voltage 120V Drivers	Input Voltage 277V Drivers
B10	277pcs	14pcs	C10	27pcs	24pcs
B13	35pcs	18pcs	C13	35pcs	31pcs
B16	43pcs	23pcs	C16	43pcs	38pcs
B20	54pcs	29pcs	C20	54pcs	48pcs
			D16	43pcs	77pcs

### Installation Precautions

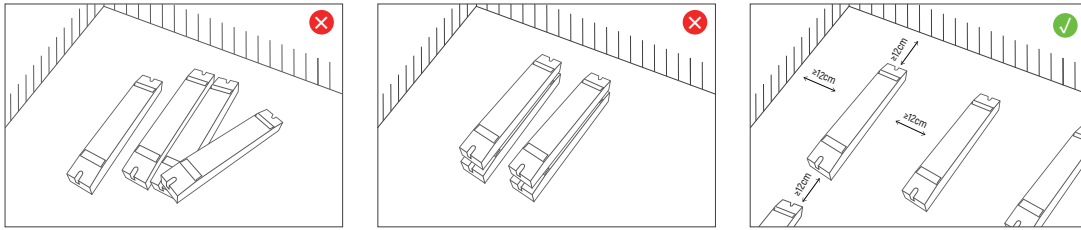

Please do not stack the products. The distance between two products should be >12cm so as not to affect heat dissipation and the lifespan of the products.

### Cautions

This product must be installed and adjusted by a qualified professional.		
1	Confirmation of installation conditions	<ul style="list-style-type: none"> <li>· <b>Waterproof and Protection:</b> Install in a suitable location according to the waterproof and protection requirements of the power supply. Products without waterproof function should be protected from direct sunlight and rain. When installing outdoors, please use a waterproof box for protection.</li> <li>· <b>Heat dissipation requirements:</b> The drive power supply should avoid exposure to high temperature environments. Please ensure that the working environment temperature is within the recommended range. To ensure proper heat dissipation of the drive power supply, a well ventilated area should be selected for installation. Good heat dissipation conditions can help extend product lifespan.</li> </ul>
2	Power check	<ul style="list-style-type: none"> <li>· Before use, check the product parameters and confirm that the output voltage and current of the LED power supply meet the requirements</li> </ul>
3	Safe wiring	<ul style="list-style-type: none"> <li>· Use cables that meet the specifications to ensure that the cross-section of the wire matches the requirements of the driving power supply. Solid cables typically measuring 0.75-2.5 mm<sup>2</sup>, (Please refer to the silk screen printing or wiring diagram in the instruction manual for specific wire diameter requirements).</li> <li>· If the power supply (metal casing) is installed on a grounded lighting component or equipment, the power supply needs to be grounded.</li> </ul>
4	Wiring confirmation	<ul style="list-style-type: none"> <li>· Before power on debugging, ensure that the wiring is secure and avoid poor contact to prevent unstable current or equipment damage.</li> </ul>
5	Repair suggestions	<ul style="list-style-type: none"> <li>· If the product malfunctions, please do not repair it without authorization. If you have any questions, please contact the supplier or sales team for assistance.</li> </ul>

※ The contents of this manual are updated without prior notice. If the function of the product you are using is inconsistent with the instructions, the function of the product shall prevail. Please contact us if you have any questions.

### Warranty Agreement

1. Warranty periods from the date of delivery : 5 years.
2. Free repair or replacement services for quality problems are provided within warranty periods.

### Warranty exclusions below:

The following situations are not covered by the free warranty or replacement service:

1. Exceeding the warranty period.
2. Damage caused by human factors such as high voltage, overload, and improper operation.
3. The appearance of the product is severely damaged or deformed.
4. Normal wear and tear or aging during regular product use.
5. Damage caused by natural disasters or force majeure factors.
6. The quality inspection label of the product is damaged (QC PASS).
7. No contract or valid invoice proof signed with EUCHIPS has been provided.

※ Remedies: Repair or replacement is the only remedy provided by EUCHIPS to the customer, and EUCHIPS shall not be liable for incidental damages arising from repair or replacement, unless within the scope of applicable law.

※ Adjustment of Warranty Terms: EUCHIPS reserves the right to modify or adjust the warranty terms, which shall be published in writing.