

MUP120AT-2W12V-BW

Product Features

- Dual channel constant voltage output, per channel 5A Max
- Input Voltage Range 120-277Vac
- Support 0-10V, Potentiometer, PWM, Triac/ELV Dimming
- 0-10V Dimming range of 0.1-100%, and dimming effect smooth, flicker free
- TRIAC and ELV dimming at 120 Vac only
- 100% output when no dimming signal input, can be used as normal power supply
- Protection: short circuit, Overload, Overcurrent
- Class 2 Output
- Safety according to UL8750 &UL 1310
- Suitable for Dry , Damp & Wet Locations

Application



LED Strip Light

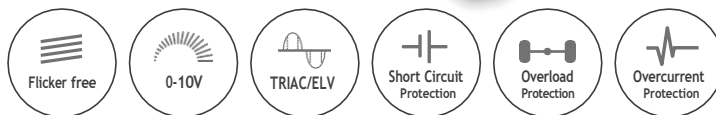

Technical Parameters

Model	MUP120AT-2W12V-BW	
Input	Efficiency	≥86%@120VAC, full load
	Voltage	120VAC-277VAC
	Frequency Range(Hz)	50/60Hz
	AC Current(max)	1.2Amax@120VAC 0.62Amax @230VAC 0.53Amax @277VAC
	PF	≥0.95@120VAC, ≥0.90@230-277VAC, full load
	THD	<10%@120VAC, <15%@230-277VAC, full load
	Inrush Current(max)	Cold start, 20.1Amax@120VAC 550us 52.2Amax@277VAC 530us
	Standby power	<3.0W@120VAC
	No load power	<3.0W@120VAC
	Turn on delay Time	<0.75s, @120Vac (When the light begins to shine)
Output	Output Current	2 Channel, 5A per channel
	Output Voltage	12VDC
	Voltage Range	12VDC ±3%
	Output Power	60W per channel, total 120W
	Output Channel	2
	Power limit	≥120%
	Ripple	≤360mV
	PWM Frequency	20KHz PWM
Function	Dimming Type	0-10V ,Triac/ELV(@120VAC 60Hz)
	Dimming Range	0.1%-100%(0-10V) 1%-100%(TRIAC/ELV)
	Dimming curve	Logarithm (for 0-10V & Triac/ELV)
	Flicker	Flicker free
Protection	Short Circuit Protection	Shut down output, Auto-recovery after Fault Clearance
	Overload Protection	Hiccup protection, Auto-recovery after Fault Clearance
	Overcurrent Protection	Hiccup protection, Auto-recovery after Fault Clearance
Safety&EMC	Surge	L-N: 4kVAC L-N-PG:6kVAC
	Withstand Voltage	I/P-O/P: 2000V/1min/<5mA I/P-G:1500V/1min/<5mA O/P-G:500V/1min/<5mA O/P-DIM(Signal port):500V/1min/<5mA
	Safety standards	UL8750, UL1310, CSA-C22.2 No. 250.13
	EMC	FCC 47 Part 15 Class B
	Insulation Resisance	5MΩ
Others	Working Temp.	(-20~+60) °C [-4° F-140° F]
	Storage Temp., Humidity	(-40~+85)°C [-40° F-185° F] 20-90%RH
	tc	75°C [167° F]
	Material	Metal
	IP Rating	IP65
	Lifetime	50,000h@tc: 75°C [167° F]
	Warranty Condition	5 years
	Switch Cycle	25,000 times
	Packing(weight)	Net weight: 1050g (2.31 lb)±5%/PCS; 12PCS/Carton;13.1kg(28.8 lb)±5%/Carton; Carton Size: 314*263*249mm(12.36*10.35*9.80 Inch)(L*W*H)
	Dimension	244*106*41.5mm (9.61*4.17*1.63 Inch)(L*W*H)

Dimension Inch (mm)

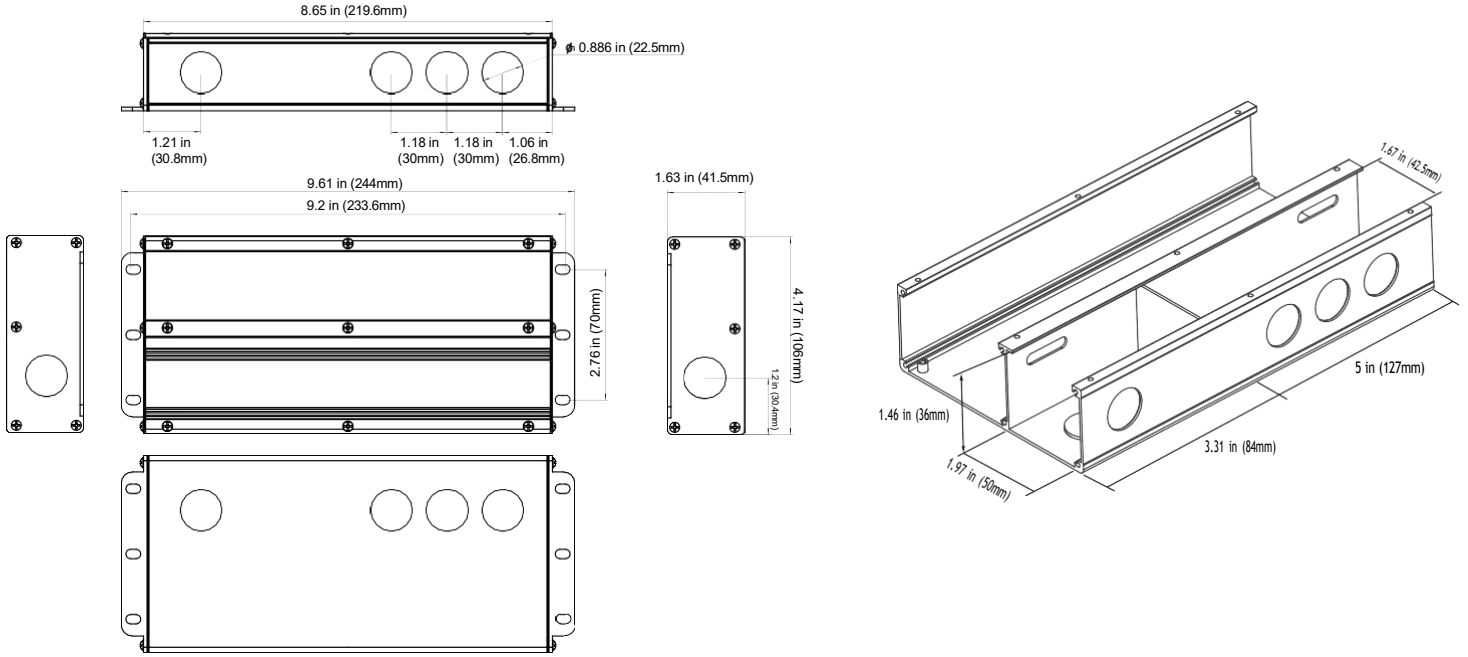

Wiring

Step 1

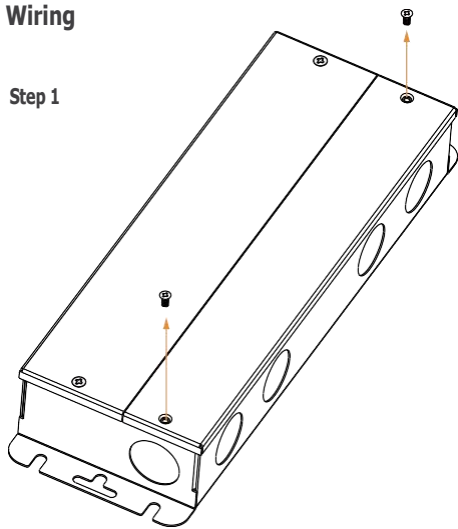

Step 2

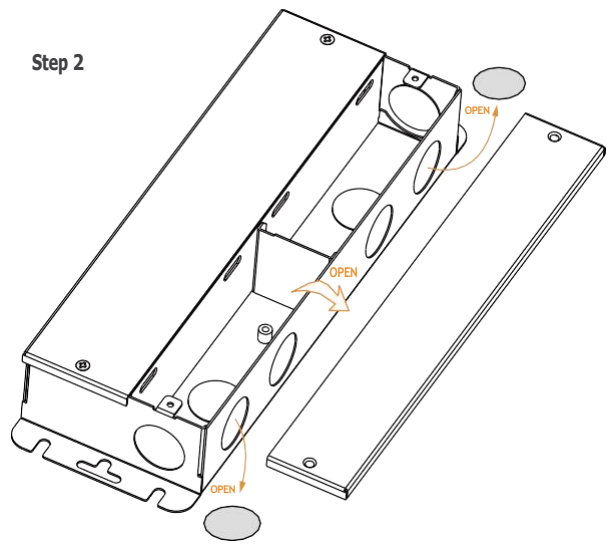

Step 3 Using Triac MLV wiring diagram

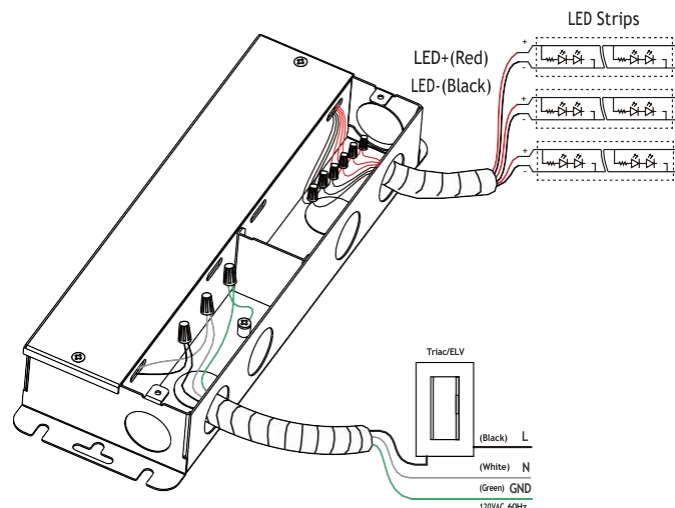

Step 4 Using Triac ELV wiring diagram

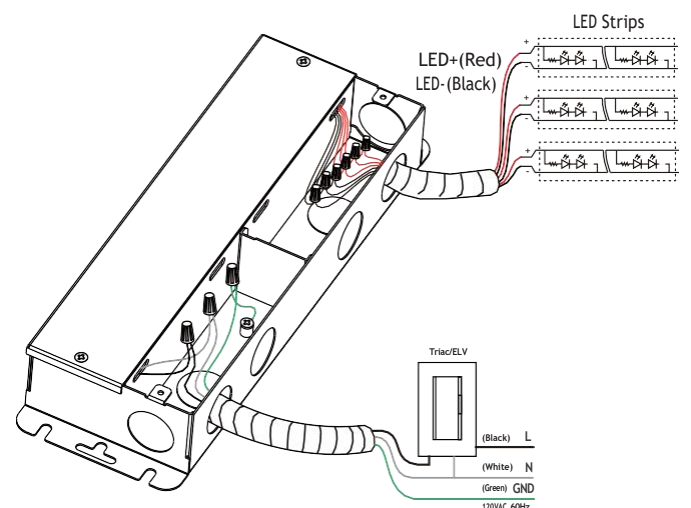

Step 5 0-10V wiring diagram

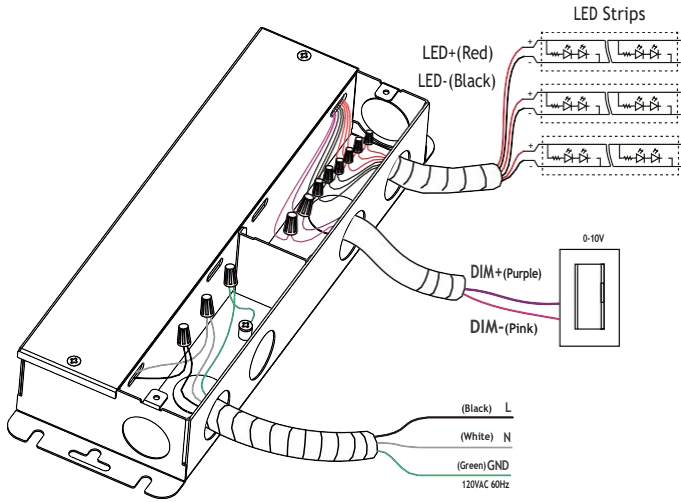

Step 6

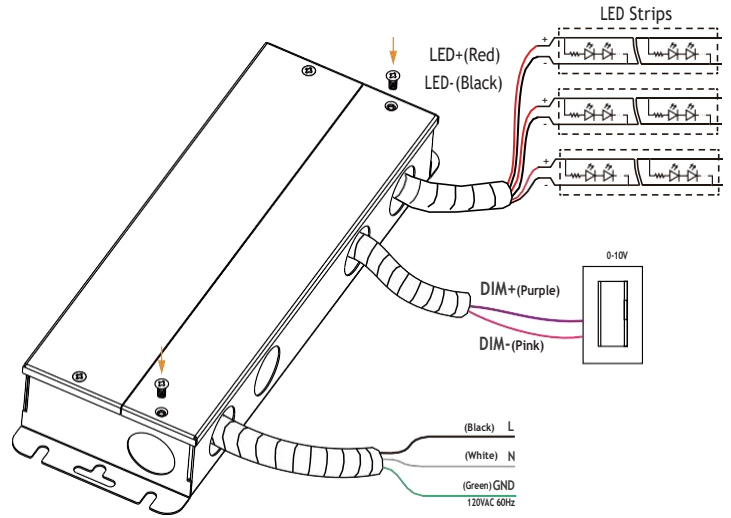

Mode switching

1. Dimming Mode Switching Window: Operation is only allowed within 30 seconds after power-on, and the device must remain powered off for at least 5 seconds before re-powering.
2. Activation Condition: The target action must be continuously maintained for 5 seconds to take effect.
3. Device Limitation: Only one dimming mode can be used at a time (e.g., if 0-10V mode is selected, a TRIAC dimming knob cannot be connected simultaneously. If TRIAC mode is selected, the 0-10V signal must remain disconnected and insulated).
4. Mode Persistence: Once a dimming mode is activated, it remains in effect until the next mode switch.

Target mode	Action requirements	Effective verification
0-10V mode	Control voltage $\leq 5V$ (hold for 5 seconds)	0-10V Mode: Normal Dimming
TRIAC/ELV Mode	Adjust the knob to 80%-50% brightness (hold for 5 seconds)	Triac/ELV Mode: Normal Dimming

TRIAC Compatible Dimmer Recommendations

Mfg.	Lutron	Lutron	Lutron	Lutron	Lutron	Lutron
Model	SCL-153P-WH	DVCL-153PR-WH	MACL-153MR-WH	CTCL-150H-LA	CTCL-153-PDH-WH	DVCL-153PH-WH

Note: "The list above recommends dimmers for TRIAC testing. Unlisted TRIAC dimmers should only be used after verification through actual testing to ensure no abnormalities. 0-10V dimming has no compatibility issues."

Max. quantity of drivers per miniature circuit breaker

Specification item	Value	Value	Condition
Inrush current I_{peak}	20.10A (120V)	52.2A (277V)	Input Voltage 120V/277V
Inrush current T_{width}	550us (120V)	530us (277V)	Input Voltage 120V/277V, measured to 50% I_{peak}

MCB	Input Voltage 120V Drivers	Input Voltage 277V Drivers	MCB	Input Voltage 120V Drivers	Input Voltage 277V Drivers
B10	6pcs	2pcs	C10	8pcs	4pcs
B13	8pcs	3pcs	C13	10pcs	5pcs
B16	10pcs	4pcs	C16	13pcs	7pcs
B20	13pcs	5pcs	C20	16pcs	9pcs
			D16	13pcs	14pcs

Installation Precautions

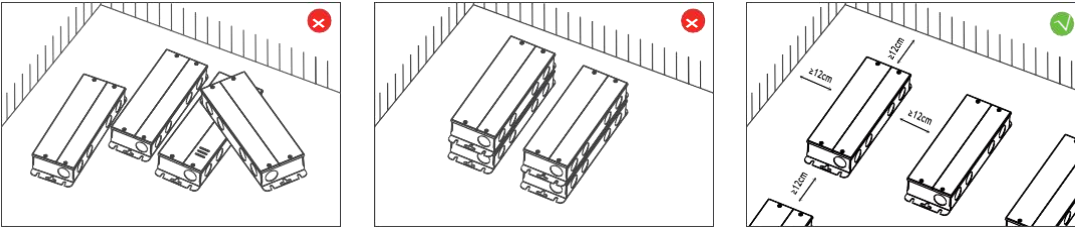

Please do not stack the products. The distance between two products should be >12cm(4.72 in) so as not to affect heat dissipation and the lifespan of the products.

0-10V Dimming Curve

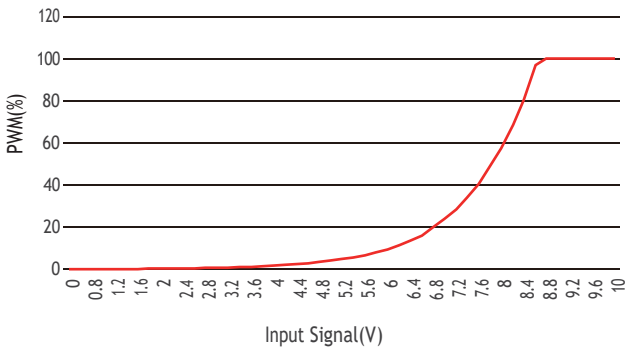

Trailing edge (ELV) Dimming Curve

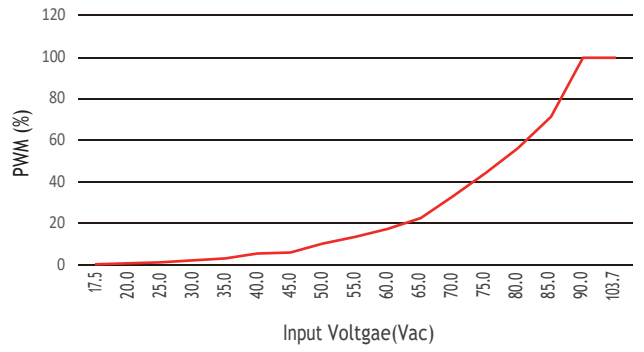

THD vs Load

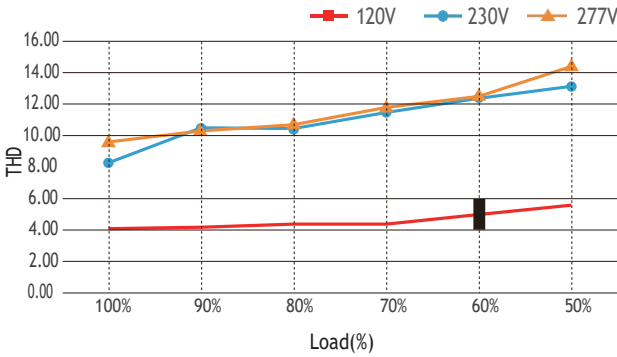

PF vs Load

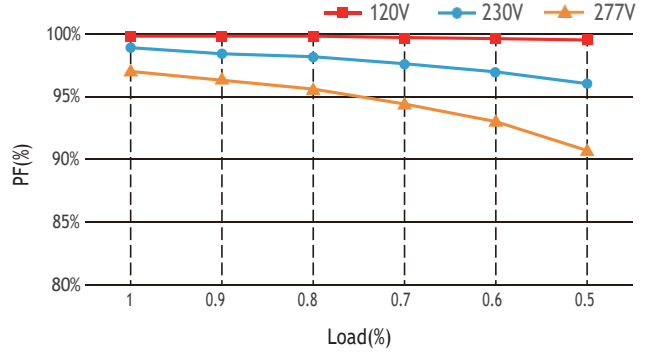

Efficiency vs Load%

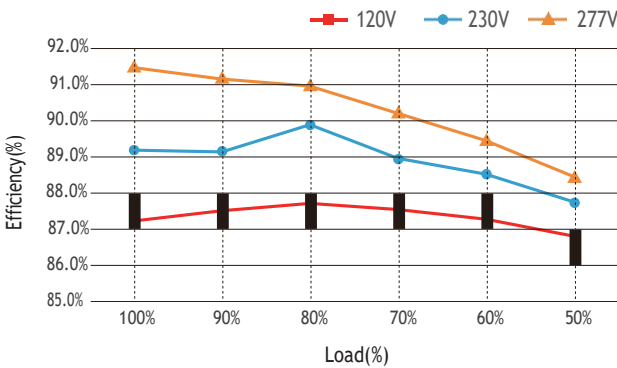

Derating Curve

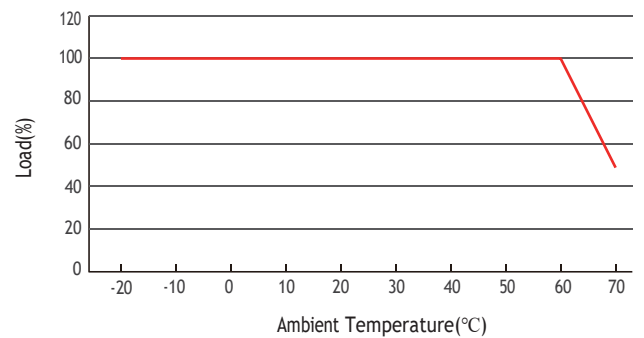

Life-time vs. case temperature

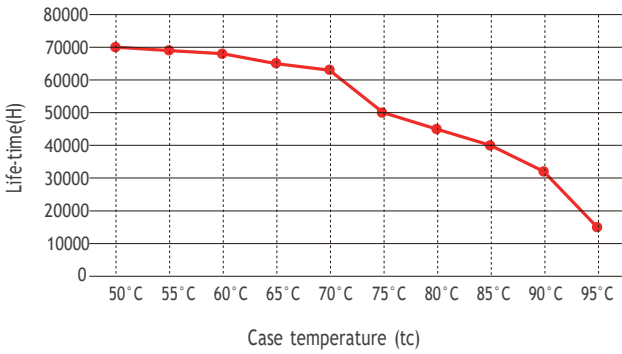

The life-time of the led driver is shown in the figure above (calculated based on the 90% survival rate).
The relation of t_c to temperature depends also on the luminaire design.

Cautions

This product must be installed and adjusted by a qualified professional.		
1	Confirmation of installation conditions	<ul style="list-style-type: none"> · Waterproof and Protection: Install in a suitable location according to the waterproof and protection requirements of the power supply. Products without waterproof function should be protected from direct sunlight and rain. When installing outdoors, please use a waterproof box for protection. · Heat dissipation requirements: The drive power supply should avoid exposure to high temperature environments. Please ensure that the working environment temperature is within the recommended range. To ensure proper heat dissipation of the drive power supply, a well ventilated area should be selected for installation. Good heat dissipation conditions can help extend product lifespan.
2	Power check	<ul style="list-style-type: none"> · Before use, check the product parameters and confirm that the output voltage and current of the LED power supply meet the requirements
3	Safe wiring	<ul style="list-style-type: none"> · Use cables that meet the specifications to ensure that the cross-section of the wire matches the requirements of the driving power supply. Solid cables typically measuring 0.75-2.5 mm², (Please refer to the silk screen printing or wiring diagram in the instruction manual for specific wire diameter requirements). · If the power supply (metal casing) is installed on a grounded lighting component or equipment, the power supply needs to be grounded.
4	Wiring confirmation	<ul style="list-style-type: none"> · Before power on debugging, ensure that the wiring is secure and avoid poor contact to prevent unstable current or equipment damage.
5	Repair suggestions	<ul style="list-style-type: none"> · If the product malfunctions, please do not repair it without authorization. If you have any questions, please contact the supplier or sales team for assistance.

※ The contents of this manual are updated without prior notice. If the function of the product you are using is inconsistent with the instructions, the function of the product shall prevail. Please contact us if you have any questions .

Warranty Agreement

1. Warranty periods from the date of delivery : 5 years.
2. Free repair or replacement services for quality problems are provided within warranty periods.

Warranty exclusions below:

The following situations are not covered by the free warranty or replacement service:

1. Exceeding the warranty period.
2. Damage caused by human factors such as high voltage, overload, and improper operation.
3. The appearance of the product is severely damaged or deformed.
4. Normal wear and tear or aging during regular product use.
5. Damage caused by natural disasters or force majeure factors.
6. The quality inspection label of the product is damaged (QC PASS).
7. No contract or valid invoice proof signed with EUCHIPS has been provided.

※ Remedies: Repair or replacement is the only remedy provided by EUCHIPS to the customer, and EUCHIPS shall not be liable for incidental damages arising from repair or replacement, unless within the scope of applicable law.

※ Adjustment of Warranty Terms: EUCHIPS reserves the right to modify or adjust the warranty terms, which shall be published in writing.