

ANS250AS-1S*

Product Feature

- Input voltage range: 180-528Vac
- Supports isolated dimming (0-10V active signal, PWM signal, resistor)
- Adjustable Output Current (AOC) with Potentiometer
- High Efficiency up to 95.5%
- Auxiliary Power: 12VDC, 200mA
- Support for external DIP switches to adjust power
- Support for external light control switch
- Protection: IUVP,SCP,OVP, OTP
- Input surge protection: Differential mode: 6kV, Common mode: 6kV(ANSI/C82 .77-5-2017)
- 5-year warranty
- Safety according to UL8750



Models

Model Number	Input Voltage Range	Max. Output Power	Output Voltage Range	Output Current Range	Default Current	Efficiency (Typ.)	PF (Typ.)	THD (Typ.)
ANS250AS-1S*	180-528Vac	250W	180-260Vdc	0.7-1.2A	1.16A	95.5%	0.95	7%

Note:

[1]. All specifications are measured at 25°C ambient temperature, input voltage 277Vac, and the typical value tested by full load

[2]. AS means 0-10V/PWM/res dimming and 12V auxiliary source.

* Means Additional Function

Models	0-10V/PWM/Res dimming	Auxiliary 12V/200mA	DIP switch	Light control switch
ANS250AS-1S	√	√		
ANS250AS-1SMC	√	√	√	
ANS250AS-1S-OP	√	√		√
ANS250AS-1SMC-OP	√	√	√	√

Technical Parameters

Model		ANS250AS-1S*				
Parameter		Min.	Typ.	Max.	Remark	
Input	Rated Input AC Voltage	200Vac	-	480Vac		
	Input AC Voltage Range	180Vac	-	528Vac	Reference derating curve	
	Frequency Range	47Hz	50/60Hz	63Hz		
	Input AC Current	-	-	1.5A	At 200Vac input and 100% load	
	Input AC Power	-	-	265W	At 200Vac input and 100% load	
	Leakage Current	-	-	0.75mA	UL 8750; 277Vac/ 60Hz	
		-	-	0.70mA	IEC 60598-1; 240Vac/ 60Hz,	
	Inrush Current	-	-	55A	At 200Vac input and 100% load, 25°C Cold Start	
		-	-	80A	At 277Vac input and 100% load, 25°C Cold Start	
		-	-	120A	At 480Vac input and 100% load, 25°C Cold Start	
	Standby Power	-	-	0.5W	At 220Vac input and Aux. power without load	
	Power Factor		0.95	0.95	-	At 277Vac , 50-60Hz, 100% load
			0.90	-	-	At 200-480Vac , 50-60Hz, 70%-100% load
THD		-	7%	10%	At 277Vac , 50-60Hz, 100% load	
		-	-	20%	At 200-480Vac, 50-60Hz, 70%-100% load	

Parameter		Min.	Typ.	Max.	Remark
Output	Output Voltage Range	180V	-	260V	
	Open Circuit Voltage	-	-	310V	
	Output Current Range	0.70A	-	1.20A	Adjustable Output Current with Potentiometer;
	Efficiency @120Vac	93.0%	94.0%	-	At 100% load and $I_o=0.96A$
	Efficiency @277Vac	94.0%	95.5%	-	At 100% load and $I_o=0.96A$
	Efficiency @347Vac	94.0%	95.5%	-	At 100% load and $I_o=0.96A$
	Output Current Tolerance	-5%	-	+5%	At 100% load
	Output Current Ripple(PK-AV)	-	5%	10%	At 100% load, 20 MHz BW
	Startup Overshoot Current	-	-	10%	At 100% load
	Turn-on Delay Time	-	-	1.0s	At 200~480Vac input and 100% load
	Line Regulation	-5%	-	+5%	At 100% load
	Load Regulation	-5%	-	+5%	
	12V Auxiliary Output Voltage	10.8V	12V	13.2V	
	12V Auxiliary Output Current	-	-	200mA	Return terminal is "Dim-"

Parameter		Min.	Typ.	Max.	Remark
0-10V Dimming	Absolute Maximum Voltage	0V	-	12V	On Dim+ Pin
	Source Current on Dim+ Pin	90uA	110uA	120uA	
	Dimming Output Range	10%loset	-	100%loset	loset<0.96A, Dimming Min. is 0.096A
	Recommended Dimming Range for 0-10V	0V	-	10V	Dimming prohibits reverse connection
	Dim Off	0.7V	0.8V	0.9V	With afterglow (standard) Without afterglow (optional)
	Dim On	0.9V	1.0V	1.1V	
PWM Dimming	PWM_in High Level	9.8V	10V	10.2V	
	PWM_in Low Level	0V	-	0.3V	
	PWM_in Frequency Range	1KHz	-	2KHz	
	PWM_in Duty Cycle	0%	-	100%	
Resistor Dimming	Resistance	0Kohm	-	100Kohm	DIM+ source current 110uA.
	Dimming Output Range	10%loset	-	100%loset	
Other Characteristics	Operating Temperature For safety(T_c)	-40°C	25°C	+90°C	
	Operating Temperature For warranty(T_c)	-40°C	25°C	+85°C	Case temperature for 5 years warranty Humidity: 10% RH to 95% RH;
	Storage Temperature(T_a)	-40°C	25°C	+85°C	
	Storage Humidity	5%RH	-	95%RH	
	Altitude	-65m	-	4000m	
	Temperature Coefficient	-0.06%/°C	-	+0.06%/°C	$T_c: 0^\circ C \sim 90^\circ C$
	Input under voltage protection	-	165Vac	180Vac	Self-recovery
	Over temperature protection	90°C	95°C	100°C	Drop current when OTP, and it can be self-recovery after the abnormality is removed.
	Short Circuit Protection	-	-	-	Self-recovery, short circuit without damage
	Lifetime($T_c \leq 85^\circ C$)	$\geq 50,000$ hours			At 277Vac,100% load, please refer to lifetime vs. case temperature curve
	MTBF	200,000 hours			At 277Vac,80% load, $T_a=25^\circ C$ (MIL-HDBK-217F)
	Warranty	5 years			$T_c \leq 85^\circ C$
	Net Weight	575g			
Dimension	198mm*52.5mm*33.5mm			L x W x H	

Note: All the parameters above are tested $T_a 25^\circ C$ and LED load, unless specified.

Safety and EMI/EMS Standards

Safety Certification	Standard	Status	Remark
UL/cUL	UL8750, CSA C22.2 No.250.13	√	
CB	IEC61347-1, IEC61347-2-13		
CE	EN 61347-1, EN 61347-2-13, EN62493		
ENEC	EN 61347-1, EN 61347-2-13, EN IEC 62384		
CCC	GB/T 19510.213, GB/T 19510.1		
SAA	AS/NZS 61347.1,AS/NZS61347.2.13		
BIS	IS15885:2012 Part 2 Sec 13		

EMC Category	Standard	Status	Remark
FCC	FCC Part15: Subpart A ANSI 63.4:2014	√	
CE	EN 55015, EN 61000-3-2, EN 61000-3-3, EN 61547		
CE	EN61000-4-2,3,4,5,6,11		
Surge	ANSI/C82 .77-5-2017		Criterion B
Ring Wave	ANSI/C82 .77-5-2017		Criterion B

Safety Test Items:

Safety Test Items	Technical Indicators		Remark
	UL Insulation Requirements	CE/ENEC Insulation Requirements	
Insulation Requirements	UL Insulation Requirements	CE/ENEC Insulation Requirements	
Input-Case	2U+1000Vac	/	Basic insulation
Input-Dim	2U+1000Vac	/	Reinforced insulation
Dim-Case	500Vac	/	Basic insulation
Insulation Resistance	≥ 10MΩ		Input-Dim,Test voltage:500Vdc
Ground Resistance	≤ 0. 1Ω		25A/1min

Note:

- LED Driver itself complies with EMC standard. However, LED Driver 's EMC should be re-checked when integrated into lighting systems due to unexpected interference of components.
- Please short L and N, LED+ and LED-, Dim+ and Dim - and Vaux+ and Vaux- when Hi-pot test.

RoHS

Our products comply with RoHS Directive (EU) 2015/863 amending Annex II to Directive 2011/65/EU.

I-V Operation Area

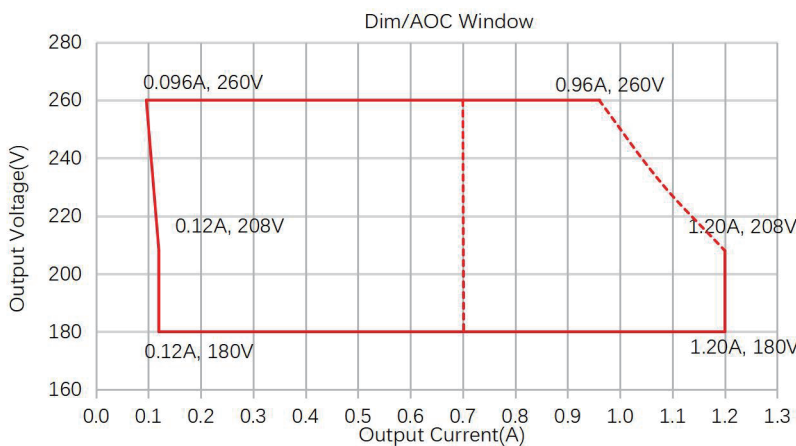

Adjustable output current

The current can be adjusted through build-in potentiometer

The table provides examples of partial currents:

Output Voltage	180Vdc	190Vdc	200Vdc	208Vdc	220Vdc	230Vdc	240Vdc	250Vdc	260Vdc
Output Current	1.20A	1.20A	1.20A	1.20A	1.14A	1.09A	1.04A	1.00A	0.96A
Output Power	216W	228W	240W	250W	250W	250W	250W	250W	250W

Derating

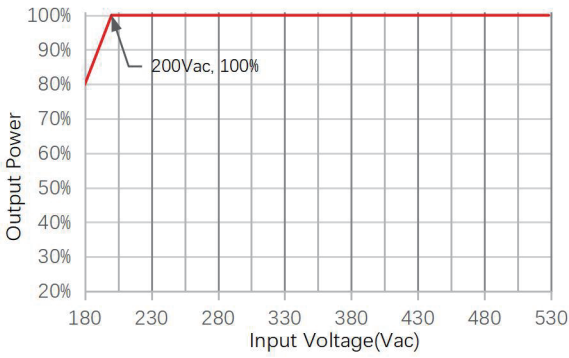

Efficiency vs. Load

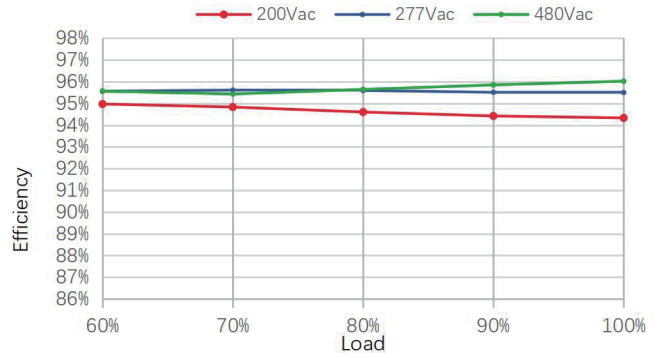

PF vs. Load

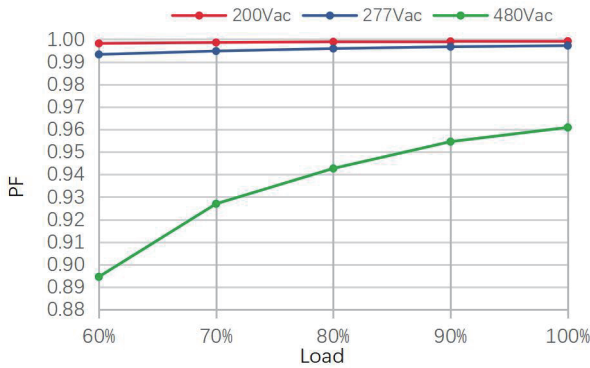

THD vs. Load

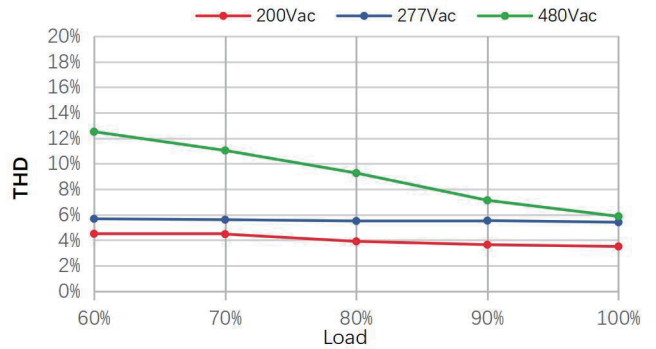

Lifetime vs. Case Temperature(Tc)

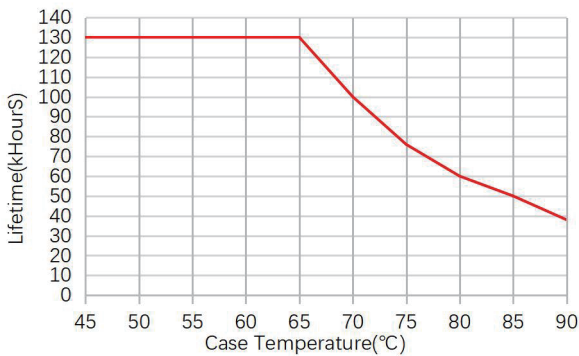

Output Power vs. Case Temperature(Tc)

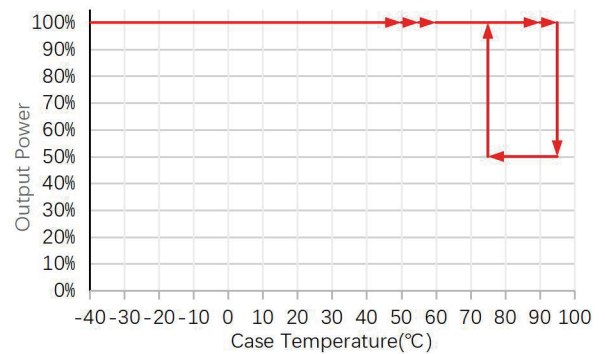

Dimming Curve

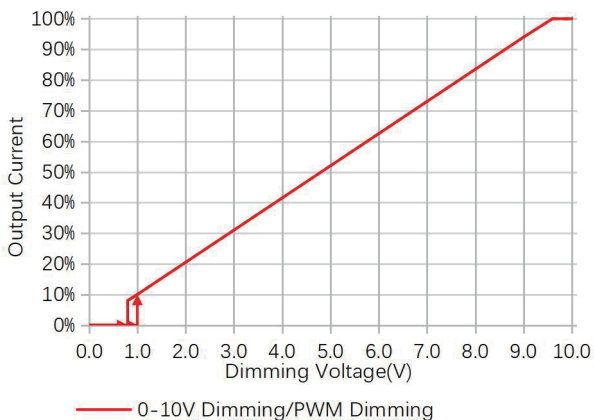

Dimension: mm (Inch)

Name Description	Standard Code	mm(In.)
Case Length	L3	190.5(7.500)
Case Width	W1	52.5(2.065)
Case Height	H	33.5(1.319)
Overall Length	L1	198(7.795)
Mounting Hole Length	L2	192(7.559)
Mounting Hole Width	W2	30(1.181)
TC Point Position	X	80(3.150)
TC Point Position	Y	22(0.866)

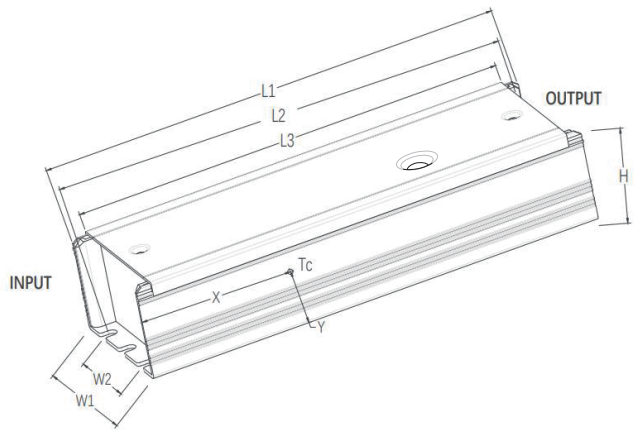

Wiring Diagram

ANS250AS-1S

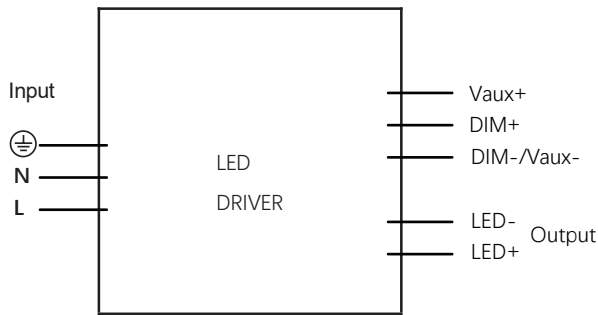

ANS250AS-1S-OP

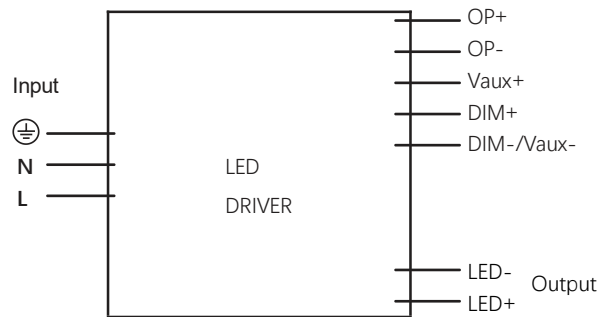

ANS250AS-1SMC

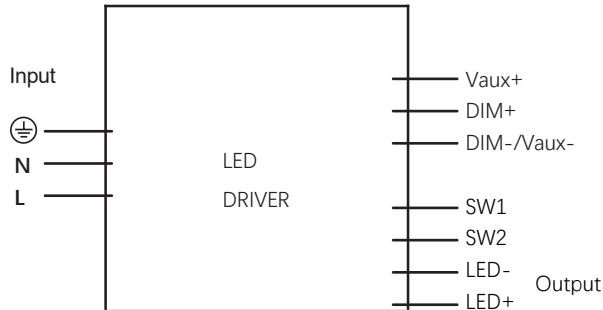

ANS250AS-1SMC-OP

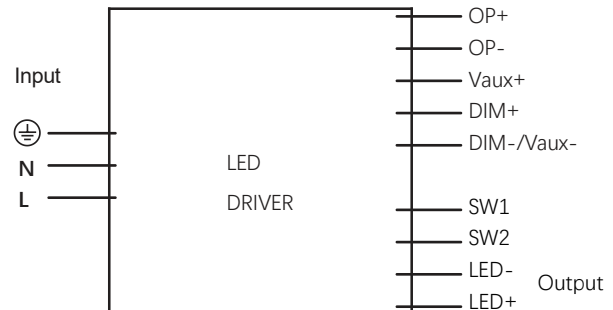

AC input wire (Exposed Wire Length: 300 ±10mm)

US Standard: UL1015 18AWG 105°C 600V, Black: L, White: N, Green: ⊕

DC output wire (Exposed Wire Length: 300 ±10mm)

US Standard: UL1569 18AWG 105°C 300V, Red: LED+, Black: LED-

DIP switch to adjust power wire

US Standard: UL1569 22AWG 105°C 300V, Orange: SW1, SW2

Light control wire with terminals

US Standard: UL3239 24AWG 200°C 3KV-DC, Red: OP+, Black: OP-

DIM signal/Aux power wire(Exposed Wire Length: 240±10mm)

US Standard: UL1569 22AWG 105°C 300V, Purple: DIM+, Black: Vaux+, Pink: DIM-/Vaux-

External DIP switch

PARAMETER	Min.	Typ.	Max.	Remark
Potentiometer adjustment range	0.70A	1.16A	1.2A	
Dial Resistance	Percentage of output current			Current after potentiometer setting
120K	50%			
180K	60%			
270K	70%			
510K	80%			
1.2M	90%			

Note

1. Recommended design within the dialling resistance range.

Max. quantity of drivers per miniature circuit breaker

	277Vac input	480Vac input	Condition
Inrush Current I _{peak}	80A	120A	
Inrush Current T _{width}	300us	300us	50%-50% I _{peak}
Inrush Current T _{width}	650us	650us	10%-10% I _{peak}

MCB	277Vac	480Vac	MCB	277Vac	480Vac
B10	4pcs	2pcs	C10	4pcs	3pcs
B13	5pcs	3pcs	C13	5pcs	5pcs
B16	6pcs	3pcs	C16	6pcs	6pcs
B20	8pcs	4pcs	C20	8pcs	7pcs
			D16	6pcs	12pcs

Inrush Current

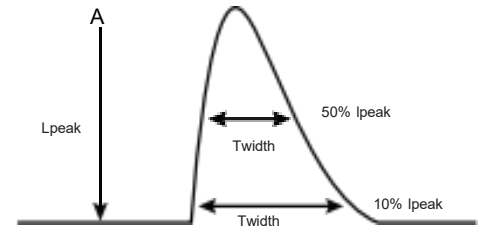

Installation Precautions

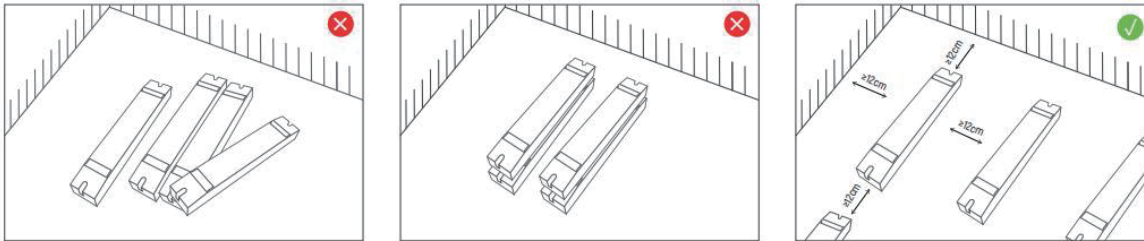

Please do not stack the products. The distance between two products should be $>12\text{cm}$ so as not to affect heat dissipation and the lifespan of the products.

Cautions

This product must be installed and adjusted by a qualified professional.		
1	Confirmation of installation conditions	<ul style="list-style-type: none"> Waterproof and Protection: Install in a suitable location according to the waterproof and protection requirements of the power supply. Products without waterproof function should be protected from direct sunlight and rain. When installing outdoors, please use a waterproof box for protection. Heat dissipation requirements: The drive power supply should avoid exposure to high temperature environments. Please ensure that the working environment temperature is within the recommended range. To ensure proper heat dissipation of the drive power supply, a well ventilated area should be selected for installation. Good heat dissipation conditions can help extend product lifespan.
2	Power check	<ul style="list-style-type: none"> Before use, check the product parameters and confirm that the output voltage and current of the LED power supply meet the requirements
3	Safe wiring	<ul style="list-style-type: none"> Use cables that meet the specifications to ensure that the cross-section of the wire matches the requirements of the driving power supply. Solid cables typically measuring $0.75\text{-}2.5\text{ mm}^2$, (Please refer to the silk screen printing or wiring diagram in the instruction manual for specific wire diameter requirements). If the power supply (metal casing) is installed on a grounded lighting component or equipment, the power supply needs to be grounded.
4	Wiring confirmation	<ul style="list-style-type: none"> Before power on debugging, ensure that the wiring is secure and avoid poor contact to prevent unstable current or equipment damage.
5	Repair suggestions	<ul style="list-style-type: none"> If the product malfunctions, please do not repair it without authorization. If you have any questions, please contact the supplier or sales team for assistance.

* The contents of this manual are updated without prior notice. If the function of the product you are using is inconsistent with the instructions, the function of the product shall prevail. Please contact us if you have any questions.

Warranty Agreement

1. Warranty periods from the date of delivery : 5 years.
2. Free repair or replacement services for quality problems are provided within warranty periods.

Warranty exclusions below:

The following situations are not covered by the free warranty or replacement service:

1. Exceeding the warranty period.
2. Damage caused by human factors such as high voltage, overload, and improper operation.
3. The appearance of the product is severely damaged or deformed.
4. Normal wear and tear or aging during regular product use.
5. Damage caused by natural disasters or force majeure factors.
6. The quality inspection label of the product is damaged (QC PASS).
7. No contract or valid invoice proof signed with EUCHIPS has been provided.

※Remedies: Repair or replacement is the only remedy provided by EUCHIPS to the customer, and EUCHIPS shall not be liable for incidental damages arising from repair or replacement, unless within the scope of applicable law.

※Adjustment of Warranty Terms: EUCHIPS reserves the right to modify or adjust the warranty terms, which shall be published in writing.

Revision history

Change date	Version	Item	
2025.12	V1.0	First release	