

ANS100AS-1W*

Product Feature

- Input voltage range: 90-305Vac
- Supports isolated dimming (0-10V active signal, PWM signal, resistor)
- Adjustable Output Current (AOC) with Potentiometer
- High Efficiency up to 96.0%
- Auxiliary Power: 12VDC, 200mA(AS Version)
- Support for external DIP switches to adjust power
- Support for external light control switch
- Protection: IUVP, SCP, OVP, OTP
- Input surge protection: Differential mode: 6kV, Common mode: 6kV(ANSI/C82.77-5-2017)
- 5-year warranty
- Safety according to UL8750

Caution/prudence

- Keep away from heat flammable materials
- Install properly for better heat dissipation
- Please do not touch during operation
- Tenir à l'écart des matériaux inflammables sous forme de chaleur
- Installer correctement pour une meilleure dissipation de la chaleur
- S'il vous plaît ne pas toucher pendant le fonctionnement

Models

| Model Number | Input Voltage Range | Max. Output Power | Output Voltage Range | Output Current Range | Default Current | Efficiency [Typ.] | PF [Typ.] | THD [Typ.] |
|--------------|---------------------|-------------------|----------------------|----------------------|-----------------|-------------------|-----------|------------|
| ANS100A-1W* | 90-305Vac | 100W | 180-260Vdc | 0.30-0.50A | 0.46A | 96.0% | 0.98 | 7% |
| ANS100AS-1W* | 90-305Vac | 100W | 180-260Vdc | 0.30-0.50A | 0.46A | 96.0% | 0.98 | 7% |

Note: All specifications are measured at 25°C ambient temperature, input voltage 220Vac, and the typical value tested by full load

* Means Additional Function

| Models | 0-10V/PWM/Res dimming | Auxiliary 12V/200mA | DIP switch | Light control switch |
|------------------|-----------------------|---------------------|------------|----------------------|
| ANS100A-1W | √ | | | |
| ANS100A-1WMC | √ | | √ | |
| ANS100A-1W-OP | √ | | √ | √ |
| ANS100AS-1W | √ | √ | | |
| ANS100AS-1WMC | √ | √ | √ | |
| ANS100AS-1W-OP | √ | √ | | √ |
| ANS100AS-1WMC-OP | √ | √ | √ | √ |

Technical Parameters

| Model | | ANS100A/AS-1W* | | | | |
|-----------|------------------------|----------------|---------|---------|---|--|
| Parameter | | Min. | Typ. | Max. | Remark | |
| Input | Rated Input AC Voltage | 120Vac | - | 277Vac | | |
| | Input AC Voltage Range | 90Vac | - | 305Vac | Reference derating curve | |
| | Frequency Range | 47Hz | 50/60Hz | 63Hz | | |
| | Input AC Current | - | - | 12A | At 120Vac input and 100% load | |
| | Input AC Power | - | - | 120W | At 120Vac input and 100% load | |
| | Leakage Current | - | - | 0.75MIU | UL 8750; 277Vac/ 60Hz | |
| | | - | - | 0.70mA | IEC 60598-1; 240Vac/ 60Hz, | |
| | Inrush Current | - | - | 35A | At 120Vac input and 100% load, 25°C Cold Start | |
| | | - | - | 60A | At 220Vac input and 100% load, 25°C Cold Start | |
| | | - | - | 75A | At 277Vac input and 100% load, 25°C Cold Start | |
| | Standby Power | - | - | 0.5W | At 220Vac input and Aux. power without load(AS Version) | |
| | Power Factor | | 0.95 | 0.98 | - | At 220Vac , 50-60Hz, 100% load |
| | | | 0.90 | - | - | At 120-277Vac , 50-60Hz, 70%-100% load |
| | THD | | - | 7% | 10% | At 220Vac , 50-60Hz, 100% load |
| | | - | - | 20% | At 120-277Vac , 50-60Hz, 70%-100% load | |



Class P IP54 RoHS



| | Parameter | Min. | Typ. | Max. | Remark |
|------------------------------|------------------------------|-------|-------|---------------------------|---|
| Output | Output Voltage Range | 180V | - | 260V | |
| | Open Circuit Voltage | - | - | 310V | |
| | Output Current Range | 0.30A | - | 0.50A | Adjustable Output Current with Potentiometer; |
| | Efficiency @120Vac | 92.5% | 94.0% | - | At 100% load and $I_o=0.385A$ |
| | Efficiency @220Vac | 94.5% | 96.0% | - | At 100% load and $I_o=0.385A$ |
| | Efficiency @277Vac | 94.5% | 96.0% | - | At 100% load and $I_o=0.385A$ |
| | Output Current Tolerance | -5% | - | +5% | At 100% load |
| | Output Current Ripple(PK-AV) | - | 5% | 10% | At 100% load, 20 MHz BW |
| | Startup Overshoot Current | - | - | 10% | At 100% load |
| | Turn-on Delay Time | - | - | 1.0s | At 120-277Vac input and 100% load |
| | Line Regulation | -5% | - | +5% | At 25°C ambient temperature, input voltage changes from 120Vac to 277Vac. |
| | Load Regulation | -5% | - | +5% | At 25°C ambient temperature, Input Voltage 240Vac, load changes from 70% to 100%. |
| | 12V Auxiliary Output Voltage | 10.8V | 12V | 13.2V | AS Version |
| 12V Auxiliary Output Current | - | - | 200mA | Return terminal is "Dim-" | |

| | Parameter | Min. | Typ. | Max. | Remark |
|-----------------------|--|---------------|-------|-----------|--|
| 0-10V Dimming | Absolute Maximum Voltage | 0V | - | 12V | On Dim+ Pin |
| | Source Current on Dim+ Pin | 90uA | 110uA | 120uA | |
| | Dimming Output Range | 10%loset | - | 100%loset | loset<0.38A, Dimming Min. is 0.038A |
| | Recommended Dimming Range for 0-10V | 0V | - | 10V | Dimming prohibits reverse connection |
| | Dim Off | 0.7V | 0.8V | 0.9V | With afterglow (standard) Without afterglow (optional) |
| | Dim On | 0.9V | 1.0V | 1.1V | |
| PWM Dimming | PWM_in High Level | 9.8V | 10V | 10.2V | |
| | PWM_in Low Level | 0V | - | 0.3V | |
| | PWM_in Frequency Range | 1KHz | - | 2KHz | |
| | PWM_in Duty Cycle | 0% | - | 100% | |
| Resistor Dimming | Resistance | 0Kohm | - | 100Kohm | DIM+ source current 110uA. |
| | Dimming Output Range | 10%loset | - | 100%loset | |
| Other Characteristics | Operating Temperature For safety(Tc) | -40°C | 25°C | +90°C | |
| | Operating Temperature For warranty(Tc) | -40°C | 25°C | +85°C | Case temperature for 5 years warranty Humidity: 10% RH to 95% RH; |
| | Storage Temperature(Ta) | -40°C | 25°C | +85°C | |
| | Storage Humidity | 5%RH | - | 95%RH | |
| | Altitude | -65m | - | 4000m | |
| | Temperature Coefficient | -0.06%/°C | - | +0.06%/°C | Tc:0 °C-90°C |
| | Input under voltage protection | - | 75Vac | 90Vac | Self-recovery |
| | Over temperature protection | 90°C | 95°C | 100°C | Drop current when OTP, and it can be self-recovery after the abnormality is removed. |
| | Short Circuit Protection | - | - | - | Self-recovery, short circuit without damage |
| | Lifetime(Tc≤90°C) | ≥50,000 hours | | | At 100% load, please refer to lifetime vs. case temperature curve |
| | MTBF | 200,000 hours | | | At 220Vac,80% load,Ta=25 °C [MIL-HDBK-217F] |
| | Warranty | 5 years | | | Tc ≤ 90°C |
| | Net Weight | 420g | | | |
| Dimension | 138mm*52.5mm*33.5mm | | | L x W x H | |

Note: All the parameters above are tested Ta 25°C and LED load, unless specified.

Safety and EMI/EMS Standards

| Safety Certification | Standard | Status | Remark |
|----------------------|---|--------|--------|
| UL/cUL | UL8750, CSA C22.2 No.250.13 | √ | |
| CB | IEC61347-1, IEC61347-2-13 | | |
| CE | EN 61347-1, EN 61347-2-13, EN62493 | | |
| ENEC | EN 61347-1, EN 61347-2-13, EN IEC 62384 | | |
| CCC | GB/T 19510.213, GB/T 19510.1 | | |
| SAA | AS/NZS 61347.1,AS/NZS61347.2.13 | | |
| BIS | ISI5885:2012 Part 2 Sec 13 | | |

| EMC Category | Standard | Status | Remark |
|--------------|--|--------|-------------|
| FCC | FCC Part15: Subpart A ANSI 63.4:2014 | √ | |
| CE | EN 55015, EN 61000-3-2, EN 61000-3-3, EN 61547 | | |
| CE | EN61000-4-2,3,4,5,6,11 | | |
| Surge | ANSI/C82 .77-5-2017 | | Criterion B |
| Ring Wave | ANSI/C82 .77-5-2017 | | Criterion B |

Safety Test Items:

| Safety Test Items | Technical Indicators | | Remark |
|-------------------------|----------------------------|---------------------------------|-------------------------------|
| Insulation Requirements | UL Insulation Requirements | CE/ENEC Insulation Requirements | |
| Input-Case | 2U+1000Vac | / | Basic insulation |
| Input-Dim | 2U+1000Vac | / | Reinforced insulation |
| Dim-Case | 500Vac | / | Basic insulation |
| Insulation Resistance | ≥10MΩ | | Input-Dim,Test voltage:500Vdc |
| Ground Resistance | ≤0.1Ω | | 25A/1min |

- Note:
- LED Driver itself complies with EMC standard. However, LED Driver 's EMC should be re-checked when integrated into lighting systems due to unexpected interference of components.
 - Please short L and N, LED+ and LED-, Dim+ and Dim - and Vaux+ and Vaux- when Hi-pot test.

RoHS

Our products comply with RoHS Directive (EU) 2015/863 amending Annex II to Directive 2011/65/EU.

I-V Operation Area

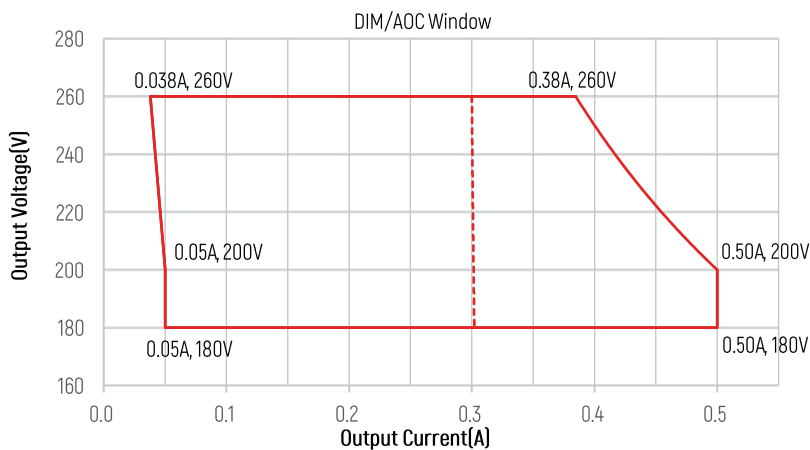

Adjustable output current

The current can be adjusted through build-in potentiometer

The table provides examples of partial currents:

| | | | | | | | | | |
|----------------|--------|--------|--------|--------|--------|--------|--------|--------|--------|
| Output Voltage | 180Vdc | 190Vdc | 200Vdc | 210Vdc | 220Vdc | 230Vdc | 240Vdc | 250Vdc | 260Vdc |
| Output Current | 0.50A | 0.50A | 0.50A | 0.48A | 0.45A | 0.43A | 0.42A | 0.40A | 0.38A |
| Output Power | 90W | 95W | 100W | 100W | 100W | 100W | 100W | 100W | 100W |

Derating

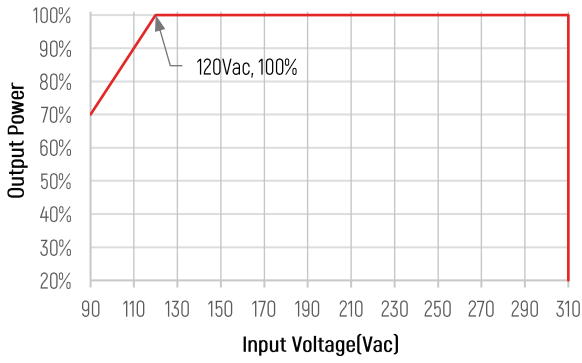

Efficiency vs. Load

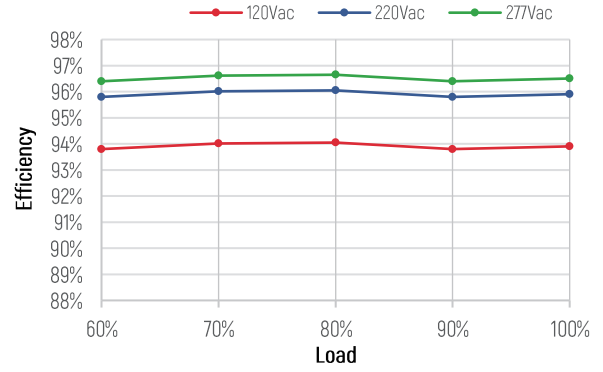

PF vs. Load

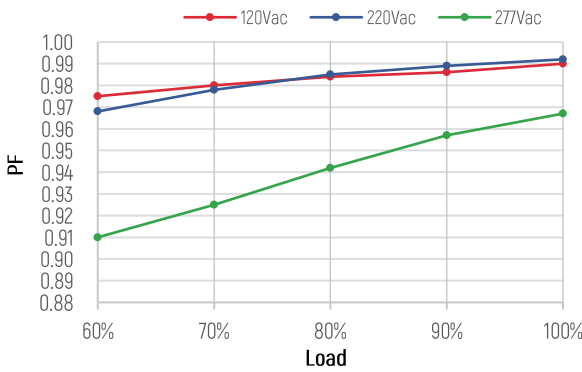

THD vs. Load

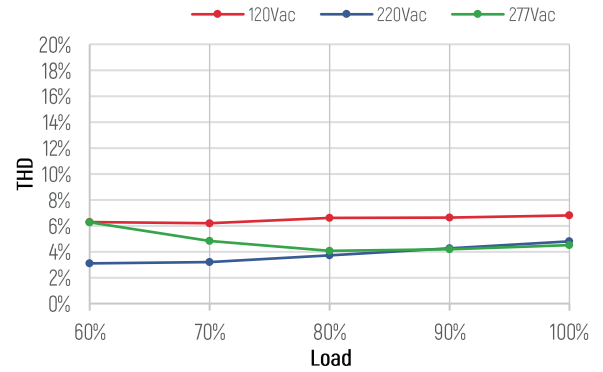

Lifetime vs. Case Temperature (Tc)

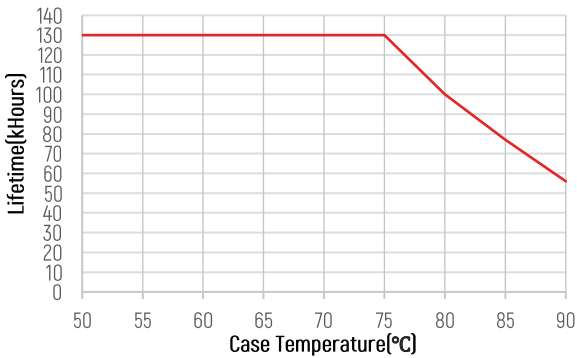

Output Power vs. Case Temperature (Tc)

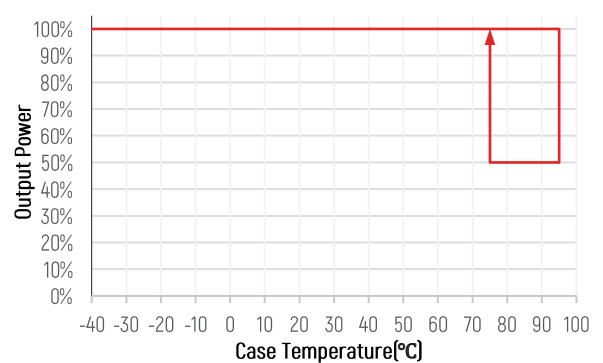

Dimming Curve

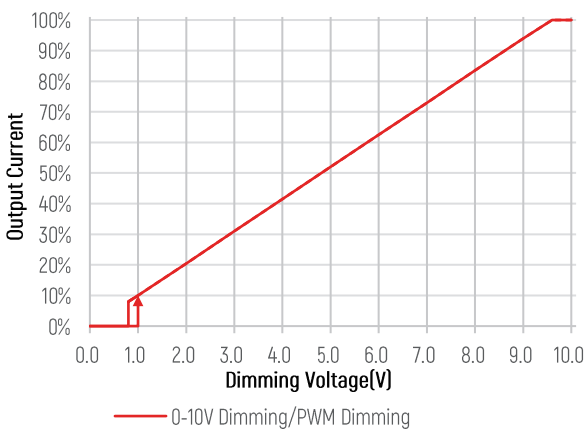

Dimension: mm (Inch)

| Name Description | Standard Code | mm(In.) |
|----------------------|---------------|--------------|
| Case Length | L3 | 130.5(5.138) |
| Case Width | W1 | 52.5(2.065) |
| Case Height | H | 33.5(1.319) |
| Overall Length | L1 | 138(5.197) |
| Mounting Hole Length | L2 | 132(5.197) |
| Mounting Hole Width | W2 | 30(1.181) |
| TC Point Position | X | 63.5(2.5) |
| TC Point Position | Y | 20(0.787) |

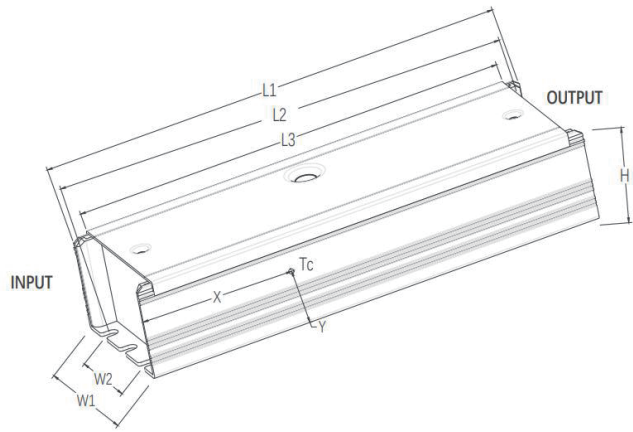

Wiring Diagram

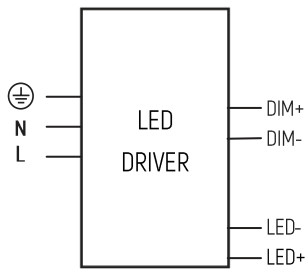

ANS100A-1W

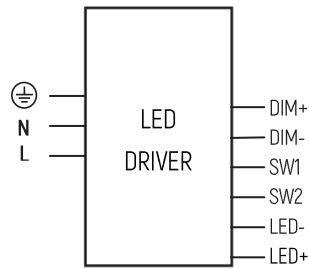

ANS100A-1WMC

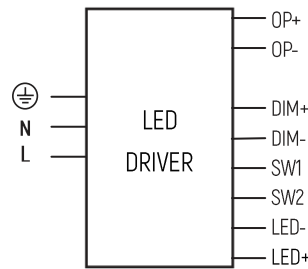

ANS100A-1WMC-OP

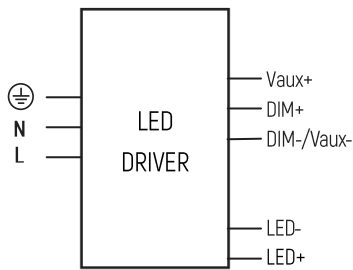

ANS100AS-1W

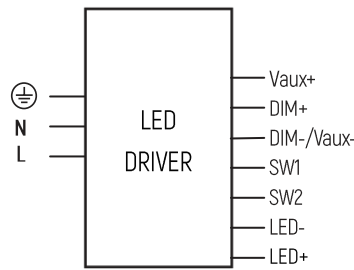

ANS100AS-1WMC

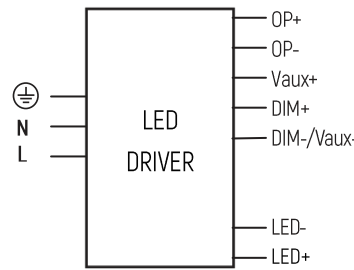

ANS100AS-1W-OP

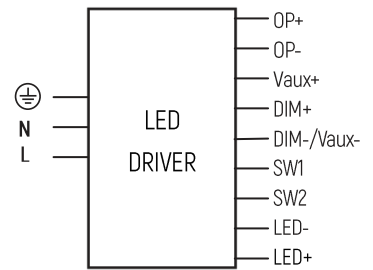

ANS100AS-1WMC-OP

AC input wire (Exposed Wire Length: 300 ±10mm)

US Standard: UL1015 18AWG 105°C 600V, Black: L, White: N, Green: ⊕

DC output wire (Exposed Wire Length: 300 ±10mm)

US Standard: UL1569 18AWG 105°C 300V, Red: LED+, Black: LED-

DIP switch to adjust power wire

US Standard: UL1569 22AWG 105°C 300V, Orange: SW1, SW2

Light control wire with terminals

US Standard: UL3239 24AWG 200°C 3KV-DC, Red: OP+, Black: OP-

DIM signal/Aux power wire(Exposed Wire Length: 240±10mm)

US Standard: UL1569 22AWG 105°C 300V, Purple: DIM+, Black: Vaux+, Pink: DIM-/Vaux-

External DIP switch

| PARAMETER | Min. | Typ. | Max. | Remark |
|--------------------------------|------------------------------|-------|-------------------------------------|--------|
| Potentiometer adjustment range | 0.30A | 0.46A | 0.50A | |
| Dial Resistance | Percentage of output current | | Current after potentiometer setting | |
| 120K | 50% | | | |
| 180K | 60% | | | |
| 270K | 70% | | | |
| 510K | 80% | | | |
| 1.2M | 90% | | | |

Note

1. Recommended design within the dialling resistance range.

Max. quantity of drivers per miniature circuit breaker

| | 120Vac input | 277Vac input | Condition |
|----------------------------------|--------------|--------------|---------------------------|
| Inrush Current I _{peak} | 35A | 75A | |
| Inrush Current Twidth | 200us | 200us | 50%-50% I _{peak} |
| Inrush Current Twidth | 450us | 450us | 10%-10% I _{peak} |

| MCB | 120Vac | 277Vac | MCB | 120Vac | 277Vac |
|-----|--------|--------|-----|--------|--------|
| B10 | 10pcs | 5pcs | C10 | 10pcs | 9pcs |
| B13 | 14pcs | 7pcs | C13 | 14pcs | 11pcs |
| B16 | 17pcs | 8pcs | C16 | 17pcs | 14pcs |
| B20 | 21pcs | 10pcs | C20 | 21pcs | 18pcs |
| | | | D16 | 17pcs | 29pcs |

Inrush Current

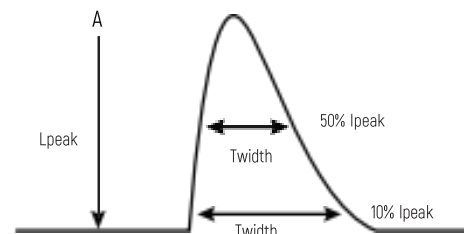

Installation Precautions

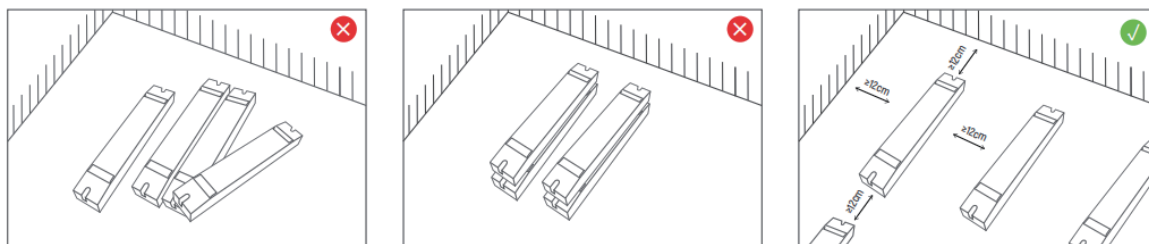

Please do not stack the products. The distance between two products should be >12cm so as not to affect heat dissipation and the lifespan of the products.

Cautions

| This product must be installed and adjusted by a qualified professional. | | |
|--|---|---|
| 1 | Confirmation of installation conditions | <ul style="list-style-type: none"> Waterproof and Protection: Install in a suitable location according to the waterproof and protection requirements of the power supply. Products without waterproof function should be protected from direct sunlight and rain. When installing outdoors, please use a waterproof box for protection. Heat dissipation requirements: The drive power supply should avoid exposure to high temperature environments. Please ensure that the working environment temperature is within the recommended range. To ensure proper heat dissipation of the drive power supply, a well ventilated area should be selected for installation. Good heat dissipation conditions can help extend product lifespan. |
| 2 | Power check | <ul style="list-style-type: none"> Before use, check the product parameters and confirm that the output voltage and current of the LED power supply meet the requirements |
| 3 | Safe wiring | <ul style="list-style-type: none"> Use cables that meet the specifications to ensure that the cross-section of the wire matches the requirements of the driving power supply. Solid cables typically measuring 0.75-2.5 mm², (Please refer to the silk screen printing or wiring diagram in the instruction manual for specific wire diameter requirements). If the power supply (metal casing) is installed on a grounded lighting component or equipment, the power supply needs to be grounded. |
| 4 | Wiring confirmation | <ul style="list-style-type: none"> Before power on debugging, ensure that the wiring is secure and avoid poor contact to prevent unstable current or equipment damage. |
| 5 | Repair suggestions | <ul style="list-style-type: none"> If the product malfunctions, please do not repair it without authorization. If you have any questions, please contact the supplier or sales team for assistance. |

※ The contents of this manual are updated without prior notice. If the function of the product you are using is inconsistent with the instructions, the function of the product shall prevail. Please contact us if you have any questions.

Warranty Agreement

- Warranty periods from the date of delivery : 5 years.
- Free repair or replacement services for quality problems are provided within warranty periods.

Warranty exclusions below:

The following situations are not covered by the free warranty or replacement service:

- Exceeding the warranty period.
- Damage caused by human factors such as high voltage, overload, and improper operation.
- The appearance of the product is severely damaged or deformed.
- Normal wear and tear or aging during regular product use.
- Damage caused by natural disasters or force majeure factors.
- The quality inspection label of the product is damaged (QC PASS).
- No contract or valid invoice proof signed with EUCHIPS has been provided.

※ Remedies: Repair or replacement is the only remedy provided by EUCHIPS to the customer, and EUCHIPS shall not be liable for incidental damages arising from repair or replacement, unless within the scope of applicable law.

※ Adjustment of Warranty Terms: EUCHIPS reserves the right to modify or adjust the warranty terms, which shall be published in writing.

Revision history

| Change date | Version | Item | From | To |
|-------------|---------|------------------------------|---------|---------|
| 2025.07 | V1.0 | First release | | |
| | V1.1 | Lifetime and product picture | Tc 85°C | Tc 90°C |
| | | | | |
| | | | | |
| | | | | |
| | | | | |
| | | | | |